



# Threaded Thru-Hulls and Scupper Valve Installation Instructions

66558 - 66567 Series

SAVE THESE INSTRUCTIONS

Form Number 69398 Rev A

03-07

These stainless steel products carry a Limited Lifetime warranty.

## WARNING:

Read instructions carefully before installing and using this product. To prevent injury, remove boat from water when installing this product and before using 120V power tools.

The stainless steel thru-hull and scupper valve must be mounted above the boat's maximum water line as determined by the boat's draft at the maximum loading recommended by the boat manufacturer. On sailboats, mount high enough on the center of the transom so fitting is above water line at all times.

## FEATURES

The stainless steel thru-hull and scupper valve have threaded ends. A seacock or in-line valve can be threaded directly onto these fittings. See chart below to match thread size.

## REQUIRED FOR INSTALLATION

- Expandable wrench (max. 2-1/2", 64mm)
- Hole saw (see chart for size)
- Cordless drill
- Polyurethane marine sealant

Thru-Hull Part Number	Thread Size (NPSM)	Thread Length	Hole Saw Size
66558	1/2"	2-1/8"	7/8"
66559	3/4"	2-1/8"	1-1/8"
66561	1"	2-1/4"	1-3/8"
66562	1-1/4"	2-1/2"	1-3/4"
66563	1-1/2"	2-3/8"	2"
66564	2"	2-1/2"	2-1/2"

Scupper Valve Part Number	Thread Size (NPSM)	Thread Length	Hole Saw Size
66565	1-1/2"	3-1/2"	2"
66567	2"	2-1/2"	2-1/2"

## THRU-HULL INSTALLATION

Mount thru-hull in the transom or side of hull, at least 12" (30cm) above maximum water line. If possible, place fitting on the same side as the steering wheel so driver can see discharge of water when the pump is working properly.

1. Use a hole saw (see chart for size – check against thru-hull) to cut hole in the transom or hull. (Figure 1)
2. Remove tightening nut. Apply a small bead of marine sealant in the groove under the flange.
3. Place thru-hull into the hole. After this point, all connections may be made from inside the hull.

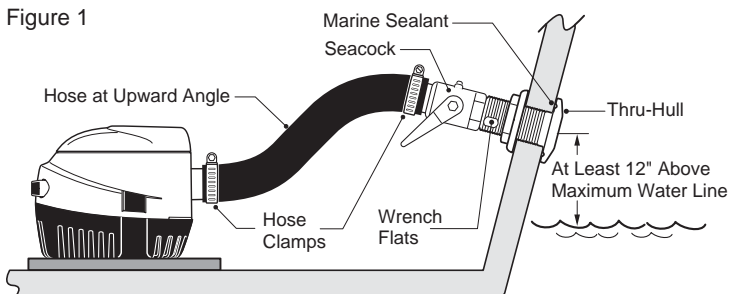

Figure 1

4. Place tightening nut onto threads, with wide side toward hull. Tighten firmly, but do not damage gelcoat by over-tightening. To prevent turning, grip wrench flats with an expandable wrench.
5. Turn seacock onto the thru-hull threads. Grip the wrench flats to hold thru-hull in place.
6. Lead hose from bilge pump to seacock at an upward angle. Fasten tightly at both ends with hose clamps.

## SCUPPER VALVE INSTALLATION

The Attwood threaded scupper valve is designed for boats with a self-bailing cockpit. The flapper valve opens outward to release water and automatically closes to help prevent backwash from entering the cockpit. Mount scupper in the transom at least 12" (30cm) above maximum water line.

1. Use a hole saw (see chart in left column for size – check against scupper) to cut hole in the transom or hull. (See Figure 2.)
2. Remove tightening nut. Apply a small bead of marine sealant in the groove under the flange.
3. Place scupper into the hole. After this point, all connections may be made from inside the hull.
4. Place tightening nut onto threads, with wide side toward hull. Tighten firmly, but do not damage gelcoat by over-tightening. To prevent turning, grip wrench flats with an expandable wrench.
5. Turn seacock onto the scupper valve threads. Grip the wrench flats to hold scupper in place.
6. Lead hose from cockpit to seacock at a downward angle. Fasten tightly at both ends with hose clamps.

Figure 2

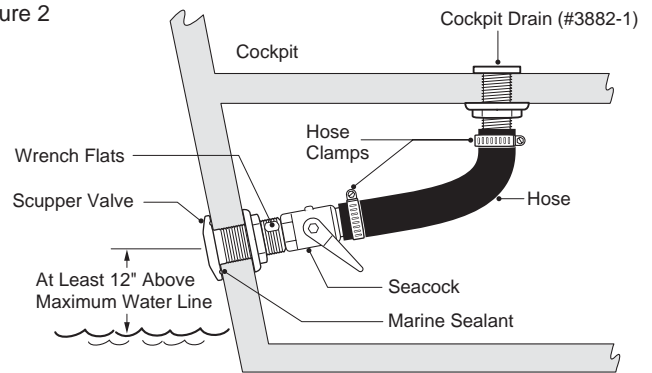

## ATTWOOD LIMITED LIFETIME WARRANTY

ATTWOOD CORPORATION, 1016 North Monroe, Lowell, Michigan 49331 ("Attwood") warrants to the original consumer purchaser that, under normal use and service, this Attwood brand product will be free from defects in materials and workmanship for the service life of the vessel on which it is originally installed. This limited warranty is not applicable if the product has been damaged by accident, improper installation, unreasonable or improper use, lack of proper maintenance, unauthorized repairs or modifications, normal wear and tear, or other causes not arising out of defects in materials or workmanship. Attwood products are warranted for use on pleasure boats. Any other use — including but not limited to commercial, racing, or non-marine use — are not covered under this warranty. Attwood's obligation under this warranty is limited to repair of the product at Attwood's plant or replacement of the products at Attwood's option without expense to the original consumer purchaser. Any expenses involved in the removal, reinstallation or transportation of the product are not covered by this warranty. The product must be returned to Attwood's plant at the address above, postage prepaid, and insured with proof of original purchase including date. If Attwood is unable to replace the product and repair is not commercially practical or cannot be timely made, or if the original consumer purchaser is willing to accept a refund in lieu of repair or replacement, Attwood may refund the purchase price, less an amount for depreciation. The acceptance by Attwood of any product returned or any refund provided by Attwood shall not be deemed an admission that the product is defective or in violation of any warranty. Products that are replaced or for which a refund is issued become the property of Attwood.

THIS WARRANTY IS ATTWOOD'S ONLY EXPRESS WARRANTY OF THIS PRODUCT. NO IMPLIED WARRANTY SHALL EXTEND BEYOND ONE (1) YEAR FROM THE DATE OF ORIGINAL CONSUMER PURCHASE. ATTWOOD SHALL NOT BE LIABLE FOR ANY DAMAGES, FOR LOSS OF USE OF THIS PRODUCT, NOR FOR ANY OTHER INCIDENTAL OR CONSEQUENTIAL DAMAGES, COSTS OR EXPENSES.

Some states do not allow the exclusion or limitation of incidental or consequential damages, so the above limitations and exclusions may not apply to you. This warranty gives you specific legal rights, and you may have other rights which vary from state to state.



# Stainless Steel Thru-Hulls and Scupper Valve Installation Instructions

66540 - 66557, 66576 - 66579 and 67550-67580 Series

SAVE THESE INSTRUCTIONS

Form Number 69373 Rev G

08-03

This product carries a limited Lifetime Warranty. See [www.attwoodmarine.com](http://www.attwoodmarine.com) or Product Catalog for details.

## WARNING:

Read all instructions carefully before installing and using this product. To prevent injury, remove boat from water when installing this product and before using 120V power tools.

The stainless steel Thru-Hull and Scupper Valve must be mounted above the boat's maximum water line as determined by the boat's draft at the maximum loading recommended by the boat manufacturer. On sailboats, mount the thru-hull high enough on the center of the transom to be above the water line at all times.

### REQUIRED FOR INSTALLATION

- Expandable wrench (max. 2-1/2", 64mm)
- Hole saw (see chart for size)
- Cordless drill
- Polyurethane marine sealant

### THRU-HULL INSTALLATION

Thru-Hull Part Number	Thread Length	Hose I.D.	Hole Saw Size	Max. Hull Thickness
66540-1	Short	5/8" I.D.	1-1/8"	5/8"
66546-1	Standard	5/8" I.D.	1-1/8"	1-1/16"
66541-1	Short	3/4" I.D.	1-1/8"	5/8"
66547-1	Standard	3/4" I.D.	1-1/8"	1-5/8"
66542-1	Short	1" I.D.	1-1/2"	5/8"
66548-1	Standard	1" I.D.	1-1/2"	1-3/4"
66543-1	Short	1-1/8" I.D.	1-1/2"	5/8"
66549-1	Standard	1-1/8" I.D.	1-1/2"	1-3/4"
66544-1	Short	1-1/4" I.D.	1-3/4"	5/8"
66550-1	Standard	1-1/4" I.D.	1-3/4"	1-7/8"
66545-1	Short	1-1/2" I.D.	2"	5/8"
66551-1	Standard	1-1/2" I.D.	2"	1-7/8"
66552-1	Standard	2"	2-1/2"	2"

### 90° Thru-Hull Part Number

66576-1	Standard	5/8" I.D.	1-1/4"	1-1/16"
66577-1	Standard	3/4" I.D.	1-1/4"	1-1/16"
66578-1	Standard	1" I.D.	1-5/8"	1-1/4"
66579-1	Standard	1-1/8" I.D.	1-5/8"	1-1/4"

### Narrow-Flange Thru-Hull Part Number

67555-1	Standard	5/8" I.D.	1-5/16"	7/8"
67554-1	Standard	3/4" I.D.	1-5/16"	3/4"
67556-1	Standard	1" I.D.	1-5/16"	7/8"
67557-1	Standard	1-1/8" I.D.	1-5/16"	3/4"
67551-1	Standard	1-1/2" I.D.	2"	1"
67558-1	Long	3/4" I.D.	1-5/16"	2-1/2" (min.1-9/16")
67562-1	Long	1-1/2" I.D.	1-15/16"	2-1/2" (min.1-9/16")
67561-1	Long	1-1/8" I.D.	1-5/16"	2-1/2" (min.1-9/16")

Mount Thru-Hull in the transom or side of hull, at least 12" (305mm) above maximum water line. If possible, place fitting on the same side as the steering wheel so the driver can see discharge of water when the pump is working properly.

1. Use a hole saw (see chart above for size – check against thru-hull) to cut hole in the transom or hull. (See Figure 1)

Figure 1

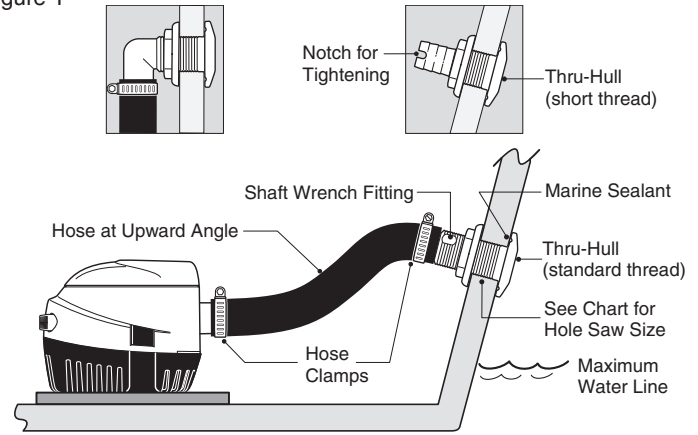

2. Remove tightening nut. Apply a small bead of marine sealant in the groove under the Thru-Hull flange.
3. Place Thru-Hull into the hole. After this point, all connections may be made from inside the hull.
4. Place tightening nut onto threads, with wide side toward hull. Tighten firmly, but do not damage gelcoat by overtightening. To prevent turning, grip the Shaft Wrench Fitting (on Standard Thread models) or the Notched End (on Short Thread models).
5. Lead hose from bilge pump to Thru-Hull at an upward angle. Fasten tightly at both ends with hose clamps.

### SCUPPER VALVE INSTALLATION

Scupper Valve Part Number	Thread Length	Hose I.D.	Hole Saw Size	Max. Hull Thickness
66557-1	Short	1-1/2" I.D.	2"	1-7/8"
66553-1	Standard	1-1/2" I.D.	2"	3"
66555-1	Standard	2" I.D.	2-1/2"	2"
67553-1	Standard	1-1/2" I.D.	2-1/8"	2-3/4"
67581-1	Standard	1-1/2"	2-3/8"	1-1/8"
67580-1	Standard	2"	2-3/8"	1-1/8"
67583-1	Standard	2-1/2"	3-5/8"	1-1/2"
67582-1	Standard	3"	3-5/8"	1-1/2"

The Attwood Stainless Steel Scupper Valve is designed for boats with a self-bailing cockpit. The flapper valve opens outward to allow water to exit and automatically closes to help prevent backwash from entering the cockpit. Mount Scupper in the transom at least 12" (305mm) above maximum water line.

1. Use a hole saw (see chart above for size - check against scupper) to cut hole in the transom or hull. (See Figure 2.)
2. Remove tightening nut. Apply a small bead of marine sealant in the groove under the Scupper flange.
3. Place Scupper Valve into the hole. After this point, all connections may be made from inside the hull.
4. Place tightening nut onto threads, with wide side toward hull. Tighten firmly, but do not damage gelcoat by overtightening. To prevent turning, grip the Shaft Wrench Fitting with an expandable wrench.
5. Lead hose (see chart above for size) from cockpit to Scupper at a downward angle. Fasten tightly at both ends with hose clamps.

Figure 2

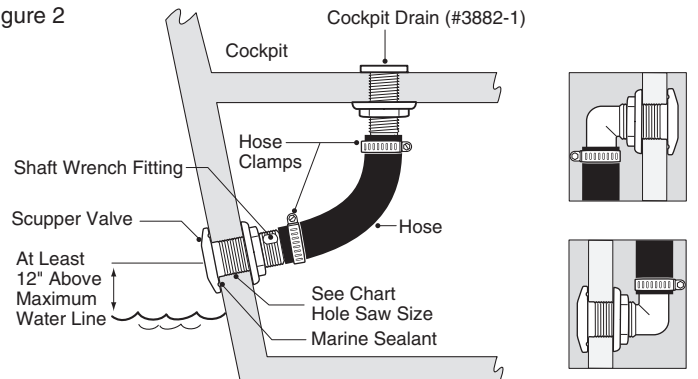

# Passe-coque et soupape de dalot en acier inoxydable

## Directives d'installation

Séries 66540 - 66557, 66576 - 66579 et 67550 - 67580

CONSERVEZ CES DIRECTIVES

Formulaire 69373 Rév G

08-03

Ce produit est assorti d'une garantie limitée à vie.

Pour plus de détails, visitez le [www.attwoodmarine.com](http://www.attwoodmarine.com) ou le catalogue des produits.

### ⚠ AVERTISSEMENT:

Lisez soigneusement toutes les directives avant d'installer ou d'utiliser ce produit.

Pour prévenir les blessures, retirez l'embarcation de l'eau lors de l'installation de ce produit et avant d'utiliser les outils mécaniques à 120V.

Le passe-coque et la soupape de dalot en acier inoxydable doivent être installés au-dessus de la ligne de flottaison maximum de l'embarcation telle que déterminée par la calaison de l'embarcation au taux de charge recommandé par le fabricant de l'embarcation. Pour les embarcations à voile, fixez le passe-coque à un endroit assez élevé au centre du tableau afin qu'il soit au-dessus de la ligne de flottaison en tout temps.

### ÉLÉMENTS REQUIS POUR L'INSTALLATION

- Clé extensible (max. 2-1/2 po, 64 mm)
- Scie à trous (pour la dimension, voir le tableau)
- Foreuse sans cordon
- Agent de scellement marin en polyuréthane

### INSTALLATION DU PASSE-COQUE

Numéro de pièce du passe-coque	Longueur du filetage	D.I. boyau	Dimension scie à trous	Épaisseur max. de la coque
66540-1	Court	5/8 po D.I.	1-1/8 po	5/8 po
66546-1	Standard	5/8 po D.I.	1-1/8 po	1-1/16 po
66541-1	Court	3/4 po D.I.	1-1/8 po	5/8 po
66547-1	Standard	3/4 po D.I.	1-1/8 po	1-5/8 po
66542-1	Court	1 po D.I.	1-1/2 po	5/8 po
66548-1	Standard	1 po D.I.	1-1/2 po	1-3/4 po
66543-1	Court	1-1/8 po D.I.	1-1/2 po	5/8 po
66549-1	Standard	1-1/8 po D.I.	1-1/2 po	1-3/4 po
66544-1	Court	1-1/4 po D.I.	1-3/4 po	5/8 po
66550-1	Standard	1-1/4 po D.I.	1-3/4 po	1-7/8 po
66545-1	Court	1-1/2 po D.I.	2 po	5/8 po
66551-1	Standard	1-1/2 po D.I.	2 po	1-7/8 po
66552-1	Standard	2 po	2-1/2 po	2 po

### Numéro de pièce du passe-coque 90°

66576-1	Standard	5/8 po D.I.	1-1/4 po	1-1/16 po
66577-1	Standard	3/4 po D.I.	1-1/4 po	1-1/16 po
66578-1	Standard	1 po D.I.	1-5/8 po	1-1/4 po
66579-1	Standard	1-1/8 po D.I.	1-5/8 po	1-1/4 po

### Étroit - Passe-coque

67555-1	Standard	5/8" I.D.	1-5/16"	7/8"
67554-1	Standard	3/4" I.D.	1-5/16"	3/4"
67556-1	Standard	1" I.D.	1-5/16"	7/8"
67557-1	Standard	1-1/8" I.D.	1-5/16"	3/4"
67551-1	Standard	1-1/2" I.D.	2"	1"

67558-1	Long	3/4" I.D.	1-5/16"	2-1/2" (min.1-9/16")
67562-1	Long	1-1/2" I.D.	1-15/16"	2-1/2" (min.1-9/16")
67561-1	Long	1-1/8" I.D.	1-5/16"	2-1/2" (min.1-9/16")

Installez le passe-coque dans le tableau ou le côté de la coque, au moins 12 po (305 mm) au-dessus de la ligne de flottaison maximum. Placez le raccord du même côté que le volant de conduite afin que le conducteur puisse voir l'eau s'échapper lorsque la pompe fonctionne correctement.

1. Utilisez une scie à trous (voir les dimensions dans le tableau ci-dessus – comparez au passe-coque) pour percer un trou dans le tableau ou la coque. (Voir la figure 1)

2. Retirez l'écrou de serrage. Appliquez un petit coulis d'agent de scellement marin dans la rainure sous la bride du passe-coque.

Figure 1

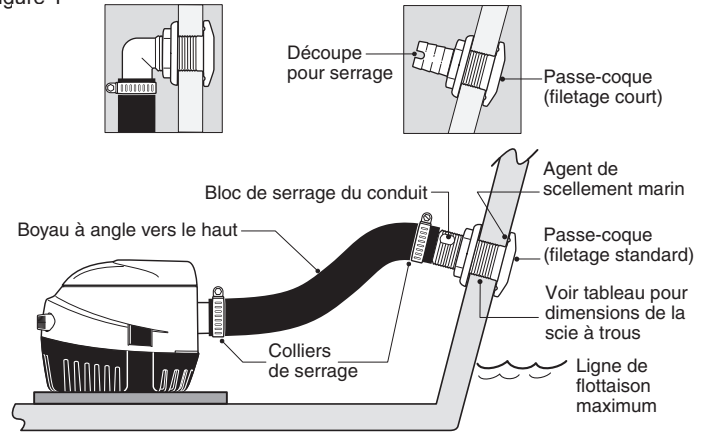

3. Placez le passe-coque dans le trou. Après avoir terminé cette étape, toutes les connexions peuvent être effectuées à partir de l'intérieur de la coque.
4. Placez l'écrou de serrage sur le filetage en assurant que son côté plus large fait face à la coque. Resserrez le fermement mais évitez d'endommager le revêtement gélifié en le serrant trop. Pour prévenir que l'écrou tourne, agrippez le bloc de serrage du conduit (sur les modèles à filetage standard) ou l'extrémité avec découpe (sur les modèles à filetage court).
5. Dirigez le boyau de la pompe de cale jusqu'au passe-coque à un angle vers le haut. Fixez fermement aux deux extrémités à l'aide de colliers de serrage.

### INSTALLATION DE LA SOUPAPE DE DALOT

Numéro de pièce soupape de dalot	Longueur du filetage	D.I. boyau	Dimension scie à trous	Épaisseur max. de la coque
66557-1	Court	1-1/2 po D.I.	2 po	1-7/8 po
66553-1	Standard	1-1/2 po D.I.	2 po	3 po
66555-1	Standard	2 po D.I.	2-1/2 po	2 po
67553-1	Standard	1-1/2 po D.I.	2-1/8 po	2-3/4 po
67581-1	Standard	1-1/2 po D.I.	2-3/8 po	1-1/8 po
67580-1	Standard	2 po D.I.	2-3/8 po	1-1/8 po
67583-1	Standard	2-1/2 po D.I.	3-5/8 po	1-1/2 po
67582-1	Standard	3 po D.I.	3-5/8 po	1-1/2 po

La soupape de dalot Attwood en acier inoxydable est conçue pour les embarcations munies d'une baignoire auto-vidieuse. La soupape à languette s'ouvre vers le dehors pour permettre à l'eau de s'échapper et se referme automatiquement pour éviter que le flot de retour s'écoule de nouveau dans la baignoire. Fixez la soupape de dalot au moins 12 (305 mm) po au-dessus de la ligne de flottaison maximum.

1. Utilisez une scie à trous (voir le tableau ci-dessus pour la taille - à vérifier en comparant au dalot) pour percer un trou dans le tableau ou dans la coque. (Voir la figure 2.)
2. Retirez l'écrou de serrage. Appliquez un petit coulis d'agent de scellement marin dans la rainure sous la bride du dalot.
3. Placez la soupape de dalot dans le trou. Après avoir terminé cette étape, toutes les connexions peuvent être effectuées à partir de l'intérieur de la coque.
4. Placez l'écrou de serrage sur le filetage en assurant que son côté plus large fait face à la coque. Resserrez-le fermement mais évitez d'endommager le revêtement gélifié en le serrant trop. Pour prévenir que l'écrou tourne, agrippez le bloc de serrage du conduit avec une clé extensible.
5. Dirigez un boyau (voir le tableau ci-dessus pour la taille) de la baignoire jusqu'au dalot à un angle incliné vers le bas. Fixez fermement aux deux extrémités à l'aide de colliers de serrage.

Figure 2

